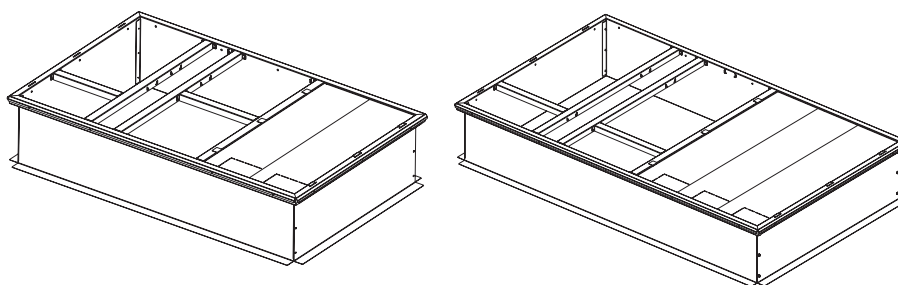

# Installer's Guide

---

## Roof Curb

### *Packaged Rooftop Units*

**Model:**

BAYCURB042A

**Used with:**

T\*C036A, 048A, 060A  
TSC060A, TSC036E, 048E, 060E  
THC033A, 043A, 063A  
Y\*C036A, 048A, 060A  
YSC060B  
YSC036E, 048E, 060E  
YHC033A, 043A, 063A  
WSC036A, 048, 060A  
WSC036E, 048E  
WSC060B

**Model:**

BAYCURB043A

**Used with:**

T\*C072A, 090A, 092A, 102A, 120A  
TSC072-120B  
Y\*C072A, 090A, 092A, 102A, 120A  
WSC060E, WSC072-120A,  
WSC072-090B

# Contents

---

<b>General Information</b> .....	3
<b>Precautionary Measures</b> .....	3
<b>Initial Inspection</b> .....	3
<b>Clearances</b> .....	3
<b>Installation</b> .....	4
<b>Roof Curb Installation for BAYCURB042A</b> .....	4
<b>Installation</b> .....	4
<b>Figure 7.</b> Curb Dimensional Data T*C033-063A, TSC060B, TSC036E, 048E, 060E, Y*C033-063A, YSC060B, YSC036E, 048E, 060E, WSC036-060A , WSC060B, WSC036E, 048E .....	6
<b>Figure 6.</b> Curb Dimensional Data T*C033-063A, TSC060B, TSC036E, 048E, 060E, Y*C033-063A, YSC060B, YSC036E, 048E, 060E, WSC036-060A , WSC060B, WSC036E, 048E .....	6
<b>Roof Curb Installation for BAYCURB043A</b> .....	7
<b>Figure 13.</b> Curb Dimensional Data — T*C072-120A, TSC072-120B, Y*C072-120A, YSC072-120B, WSC060E, WSC072-120A, WSC072-090B .....	9
<b>Figure 14.</b> Curb Dimensional Data — T*C072-120A, TSC072-120B, Y*C072-120A, YSC072-120B, WSC060E, WSC072-120A, WSC072-090B .....	9
<b>Figure 15.</b> Roof construction .....	10
<b>Figure 16.</b> Existing roof construction .....	10
<b>Figure 17.</b> Center of gravity .....	12

# General Information

---



## WARNING

Indicates a potentially hazardous situation which, if not avoided, could result in death or serious injury.



## CAUTION

Indicates a potentially hazardous situation which, if not avoided, may result in minor or moderate injury. It may also be used to alert against unsafe practices.

## CAUTION

Indicates a situation that may result in equipment or property-damage-only accidents.

## General

This manual describes the layout and installation procedures required to properly assemble and install the roof curb. Illustrations in Figure 7 for T\*C033-063A, TSC060B, TSC036E, 048E, 060E, Y\*C033-063A, YSC060B, YSC036E, 048E, 060E, WSC036-060A, WSC060B, WSC036E, 048E units or Figure 15 for T\*C072-120A, TSC072-120B, Y\*C072-120A, YSC072-120B, WSC060E, WSC072-120A, WSC072-090B units are provided for dimensional data regarding roof opening construction.

Each curb package ships unassembled, along with the required hardware and gasketing material. Roof insulation, cant strips, flashing (if desired), nails, and sheet metal screws must be furnished by the installing contractor.

**Note:** ***Important - DO NOT discard EPS foam panels included in this kit. They are used for insulating the condenser section of the roof curb. Follow instructions for installation.***

## Initial Inspection

Compare the order number on the shipping label with the accessory identification information on the ordering and shipping documents to verify that the correct accessory has been received.

## Clearances

The recommended clearances for single-unit installations are illustrated in Figure 6 for T\*C033-063A, TSC060B, TSC036E, 048E, 060E, Y\*C033-063A, YSC060B, YSC036E, 048E, 060E, WSC036-060A, WSC060B, WSC036E, 048E units or Figure 13 for TT\*C072-120A, TSC072-120B, Y\*C072-120A, YSC072-120B, WSC060E, WSC072-120A, WSC072-090B units.

These minimum requirements are not only an important consideration when determining unit placement, but they are also essential to ensure adequate serviceability, maximum capacity, and peak operation efficiency.

Any reduction of the unit clearances indicated in this illustration may result in condenser coil starvation, or the recirculation of warm condenser air. Actual clearances which appear to be inadequate should be reviewed with a local sales engineer.

# Installation

## Installation

Read the entire manual carefully to become familiar with the roof curb installation procedures. If the roof curb will be mounted on a new building, it can be assembled at any convenient location and installed as soon as the roof support members are in place. As a general rule, the curb should be placed directly on the roof support members. Use tack welding or other suitable fastening method to secure the roof curb in place.

The curb can also be mounted on a roof deck. In this case, additional nailing plates must be provided directly below the flanges of the curb to give further support and to minimize vibration. See Figures 15 and 16.

When the installation is on an existing building, hoist the shipping container directly onto the roof.

## Supply and Return Air Ductwork

All ductwork must be run and attached to the curb before the unit is set into place.

All ductwork must be fabricated and installed by the installing contractor. To ensure proper duct construction and installation, SMACNA recommendations should be closely followed.

Note: All field fabricated panels used must be insulated. (See Figure 5 or Figure 12 ).

## Roof Opening

For safety and sound considerations, do not cut out the entire roof deck within the curb area.

## Roof Support

The roof must be capable of adequately supporting the weight of the rooftop unit as well as that of the curb; refer to Figure 17 and Tables 1 and 2 for specific center-of-gravity, corner weight information and accessory weights.

Units may be set either lateral or parallel to the roof support members. The combined weight of the unit, accessories, and curb should be evenly spaced between a minimum of two (2) supports.

Ensure that the curb's position on the roof supports does not interfere with the clearance required for the supply/return ductwork. See Figure 7 for T\*C033-063A, TSC060B, TSC036E, 048E, 060E, Y\*C033-063A, YSC060B, YSC036E, 048E, 060E, WSC036-060A, WSC060B, WSC036E, 048E units or Figure 14 for T\*C072-120A, TSC072-120B, Y\*C072-120A, YSC072-120B, WSC060E, WSC072-120A, WSC072-090B units.

**Note:** For convenience, it is suggested that the starting collars for the supply and return ductwork be installed before the curb is placed into position.

## Roof Curb Installation for BAYCURB042A

**T\*C033-063A, TSC060B, TSC036E, 048E, 060E, Y\*C033-063A, YSC060B, YSC036E, 048E, 060E, WSC036-060A, WSC060B, WSC036E, 048E**

### Parts List

- 2 ends
- 2 sides
- 3 long duct supports
- 2 short duct supports
- 3 insulation supports
- 2 sheets of EPS foam insulation
- Gasket
- These instructions

There are more attachment locations (raised triangular shaped corner slots) than actual component attachments; to assemble the roof curb, you will need a tape measure to assure components are in the correct orientation. Locate the correct attachment slots for the internal supports using the dimensions from the diagram.

1. Set the two (2) sides and two (2) ends on a flat surface to form a square, with the wood nailers facing the outside. Assembling a long duct support at this point will hold the sides in place while fastening ends.
2. Screw the sides and ends together with the 1/4x5/8 screws provided.
3. Assemble a long (37.42") duct support between the two sides: insert the first duct support 14.5 inches from either end by inserting the tabs on each end of the duct support into the appropriate triangular shaped slots. See [Figure 1, p. 5](#). For your convenience we have provided screws and screw holes for securing each duct support. Use one screw for each end of a long duct support. These screws are not necessary for strength or function, but are to prevent accidental disassembly during duct attachment.
4. Insert the other two long duct supports as shown. See [Figure 2, p. 5](#). Verify the 4.88" and 16.75" dimensions between long duct supports.
5. Locate the position for the short duct support, 10.49" from the side, that fits between the first long duct support and the end. Insert the support flanges into the appropriate corner catches. Verify the 10.49" dimension. See [Figure 3, p. 5](#)
6. Insert the second short duct support between the middle and left long duct supports. Verify the 17.84" dimension from the duct support to the side. See [Figure 3, p. 5](#)
7. Insert the three (3) insulation supports between the left end and the closest long duct support, being sure to insert the tabs into the slots in the top of the end piece. See [Figure 3, p. 5](#).
8. Install insulation and gasket. See [Figure 4, p. 5](#) and [Figure 5, p. 5](#).

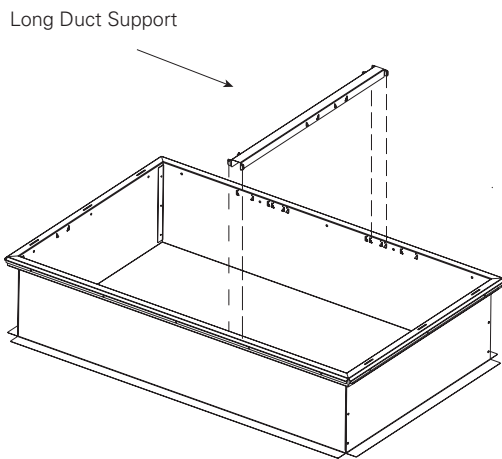

**Figure 1. Step one**

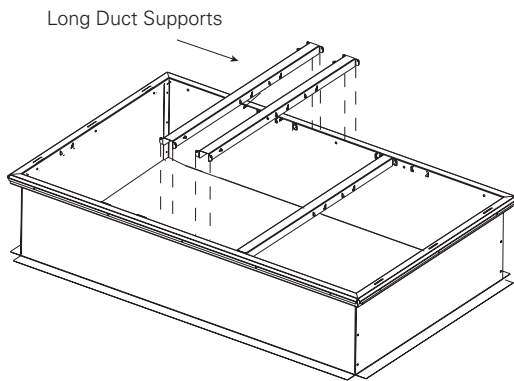

**Figure 2. Step two**

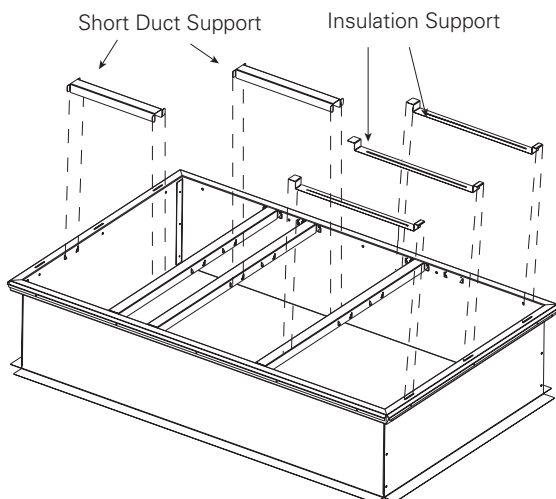

**Figure 3. Step three**

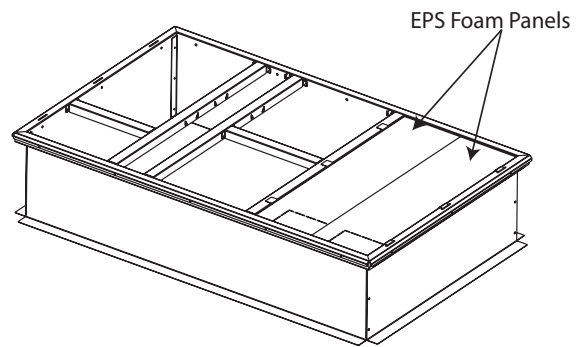

**Figure 4. Step four**

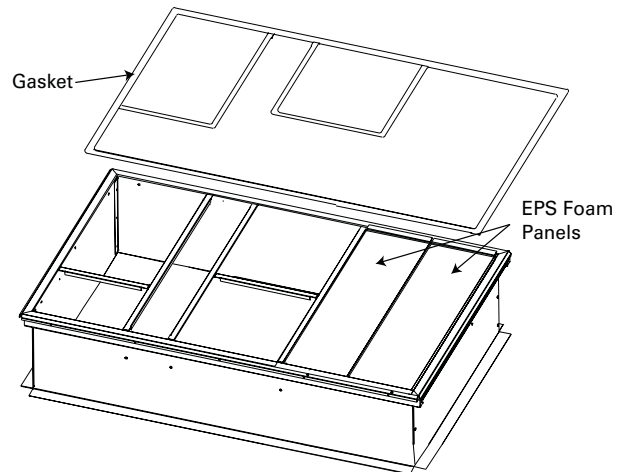

**Figure 5. Step five**

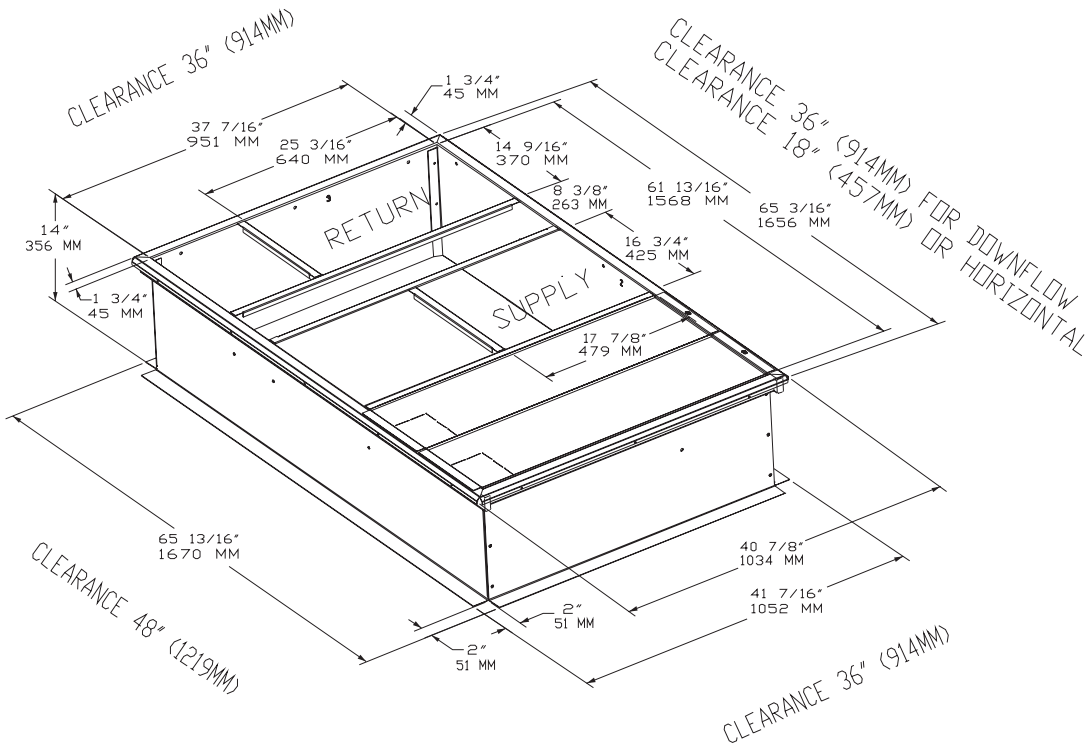

Figure 6. Curb Dimensional Data T\*C033-063A, TSC060B, TSC036E, 048E, 060E, Y\*C033-063A, YSC060B, YSC036E, 048E, 060E, WSC036-060A , WSC060B, WSC036E, 048E

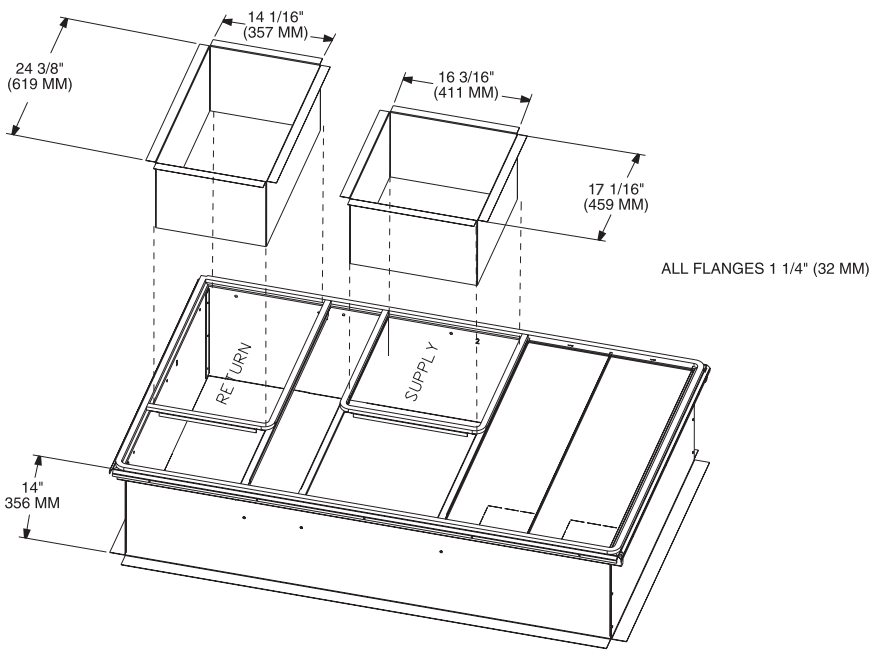

Figure 7. Curb Dimensional Data T\*C033-063A, TSC060B, TSC036E, 048E, 060E, Y\*C033-063A, YSC060B, YSC036E, 048E, 060E, WSC036-060A , WSC060B, WSC036E, 048E

### Roof Curb Installation for BAYCURB043A

T\*C072-120A, TSC072-120B,  
Y\*C072-120A, YSC072-120B,  
WSC060E, WSC072-120A,  
WSC072-090B

#### Parts List

- 2 ends
- 2 sides
- 3 long duct supports
- 2 short duct supports
- 3 insulation supports
- 3 sheets of EPS foam insulation
- Gasket
- These instructions

There are more attachment locations (raised triangular shaped corner slots) than actual component attachments, so to assemble the roof curb, you will need a tape measure to assure components are in the correct orientation. Use the dimensions from the diagram to locate the correct attachment slots for the internal supports.

1. Set the two (2) sides and two (2) ends on a flat surface to form a square, with the wood nailers facing the outside. See [Figure 8, p. 8](#). Assembling a long duct support at this point will hold the sides in place while fastening ends.
2. Screw the sides and ends together with the 1/4x5/8 screws provided.
3. Assemble a long (46.18") duct support between the two sides

(Return section): insert the first duct support 18.43 inches from either end by inserting the tabs on each end of the duct support into the appropriate triangular shaped slots. See [Figure 9, p. 8](#). For your convenience we have provided screws and screw holes for securing each duct support. Use one screw for each end of a long duct support. These screws are not necessary for strength or function, but are to prevent accidental disassembly during duct attachment.

4. Insert the other two long duct supports as shown on the top view (Supply Section). See [Figure 9, p. 8](#). Verify the 5.18" and 18.45" dimensions between long duct supports.
5. At 10.25" from the side, locate the position for the short duct support that fits between the first long duct support and the end. Insert the support flanges into the appropriate corner catches. Verify the 10.27" dimension. See [Figure 10, p. 8](#).
6. Insert the second short duct support between the middle and left long duct supports. Verify the 10.27" dimension from the duct support to the side (in line with previously assembled short duct support). See [Figure 10, p. 8](#).
7. Insert the three (3) insulation supports between the left end and the closest long duct support, being sure to insert the tabs into the slots in the top of the end piece. See [Figure 11, p. 8](#).
8. Install three pieces of foam insulation and gasket. See [Figure 12, p. 8](#).

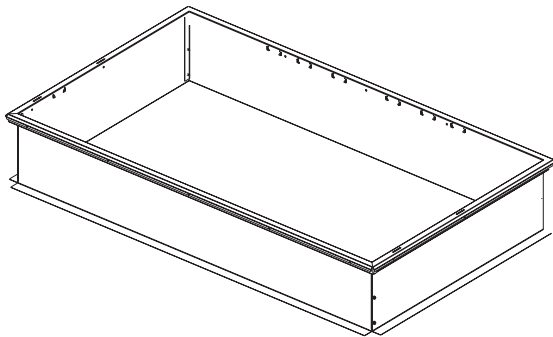

Figure 8. Step one

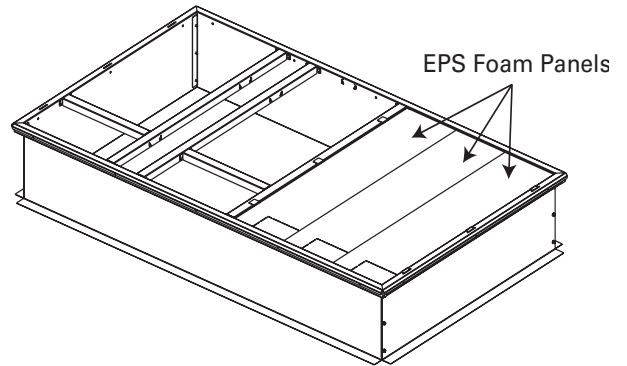

Figure 11. Step four

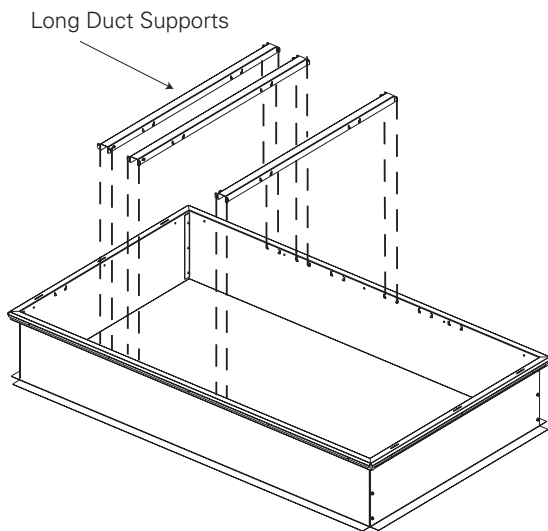

Figure 9. Step two

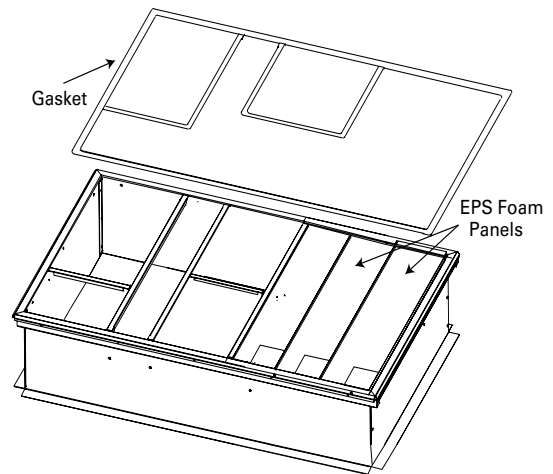

Figure 12. Step five

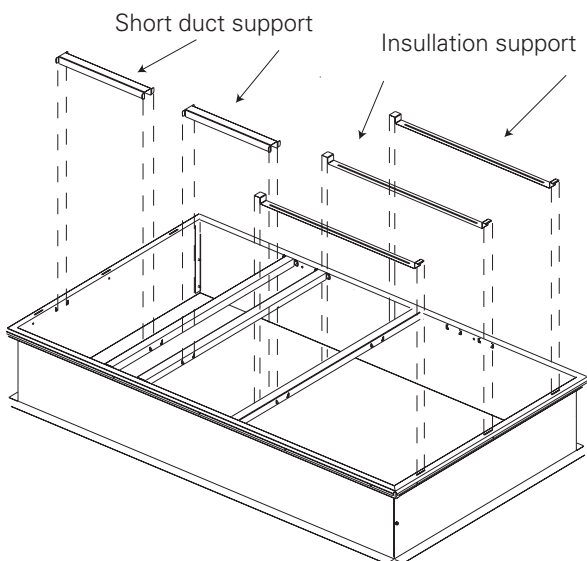

Figure 10. Step three



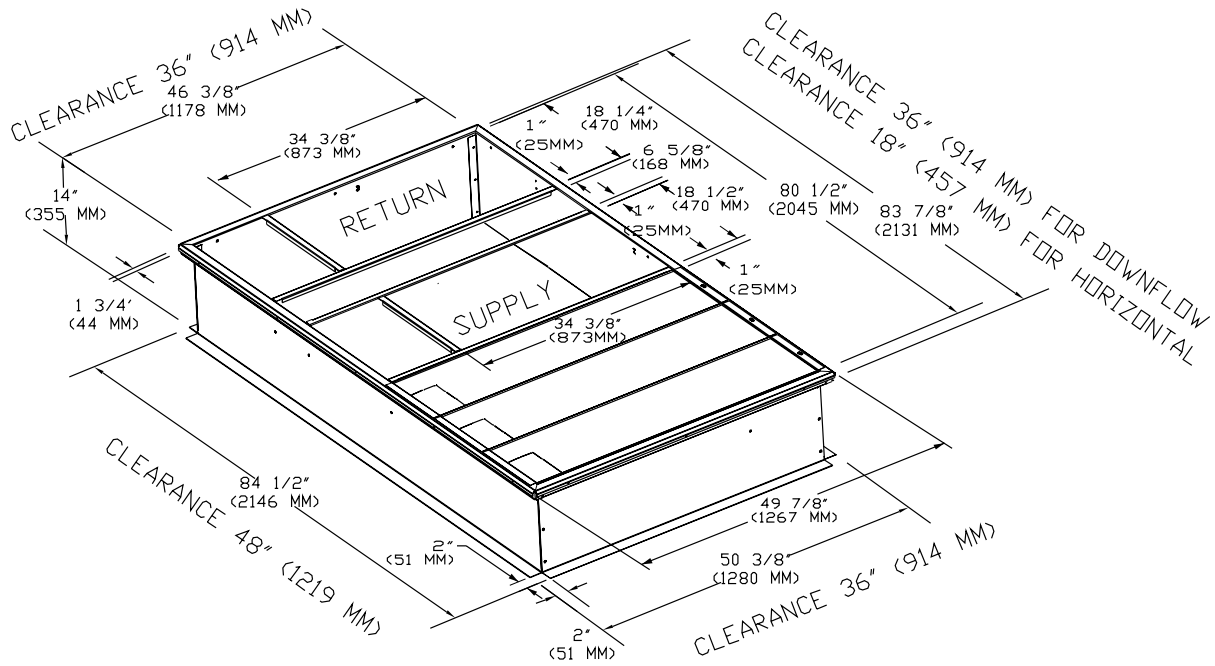

Figure 13. Curb Dimensional Data — T\*C072-120A, TSC072-120B, Y\*C072-120A, YSC072-120B, WSC060E, WSC072-120A, WSC072-090B

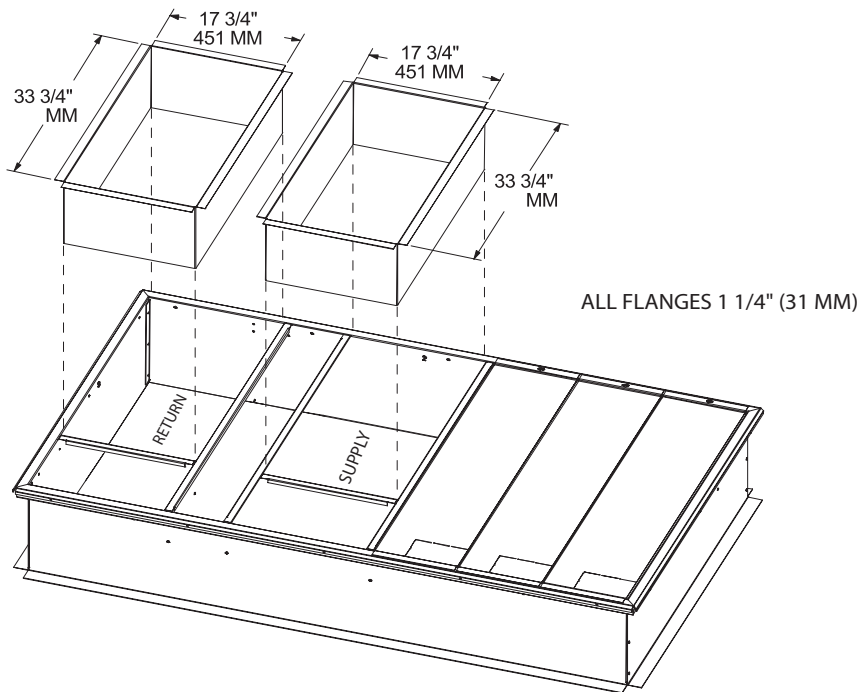
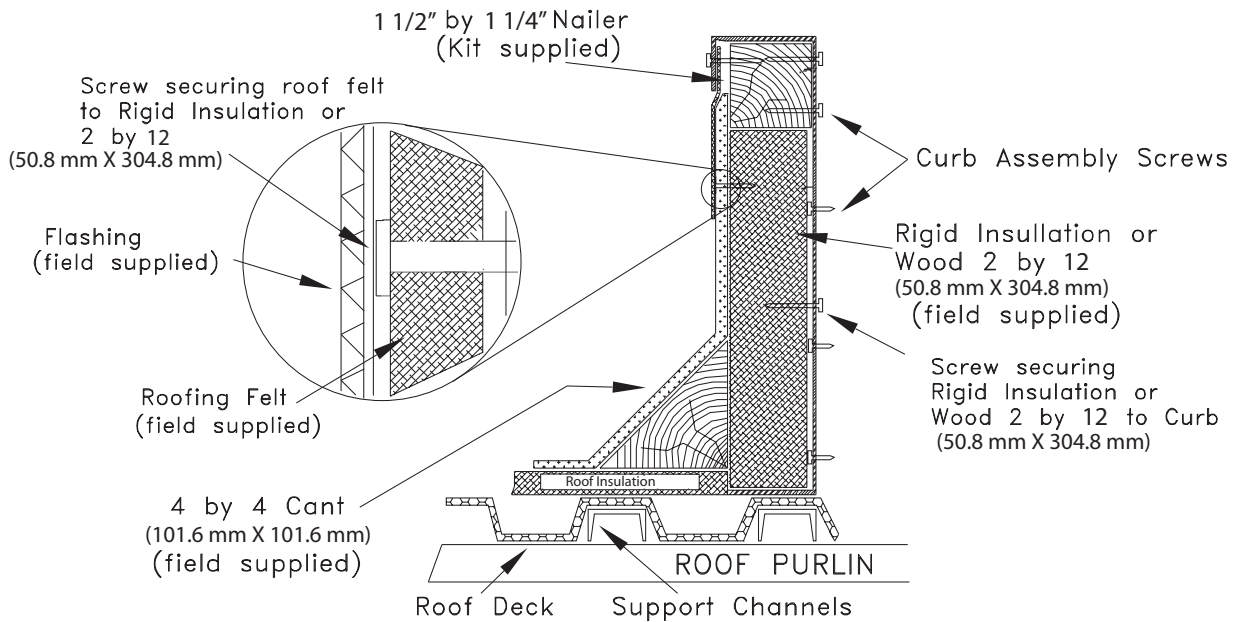
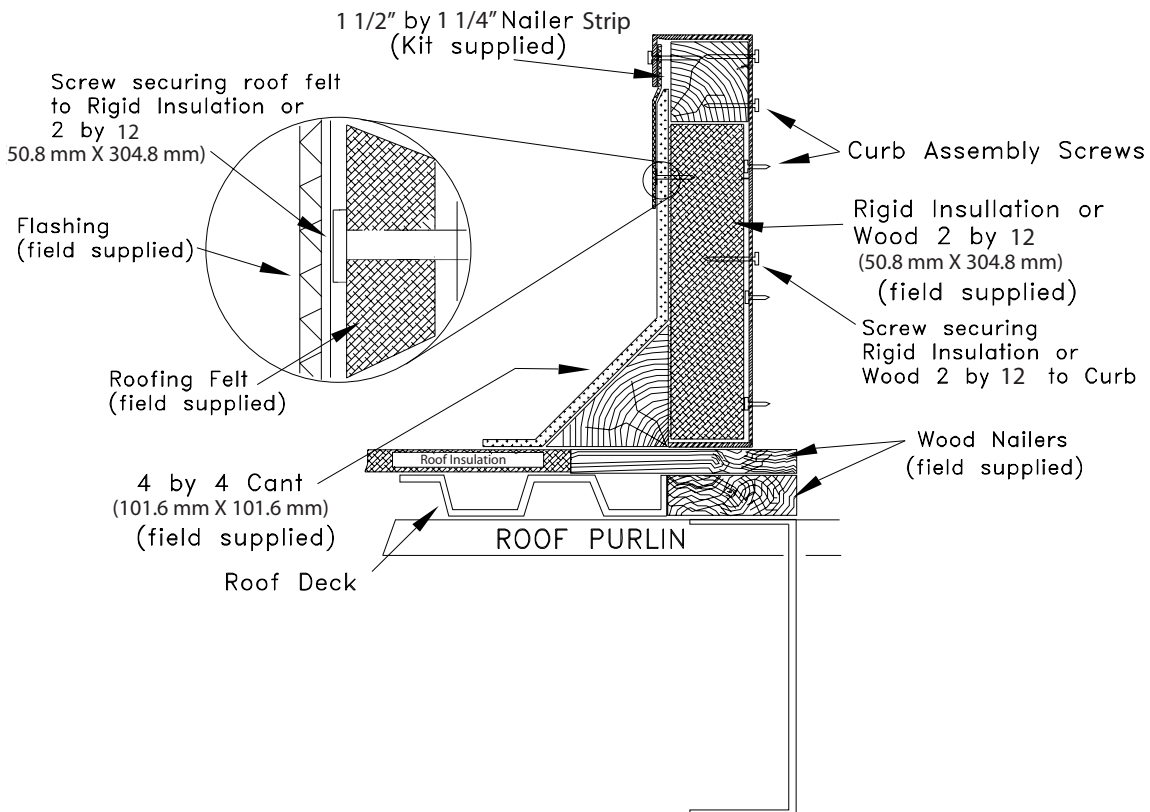

Figure 14. Curb Dimensional Data — T\*C072-120A, TSC072-120B, Y\*C072-120A, YSC072-120B, WSC060E, WSC072-120A, WSC072-090B

# Installation



**Figure 15. Roof construction**



**Figure 16. Existing roof construction**

# Installation

**Table 1. Cooling corner weights and center of gravity**

Unit Model	Net Weight	Corner Weight				Center of Grav.	
		A	B	C	D	Length	Width
TSC036E(1,3,4,W)	80	157	122	95	107	31	19
TSC036A(1,3,4,W)*	409	132	104	79	94	31	19
TSC048A1*	434	140	110	91	94	32	19
TSC048A(3,4,W)*	421	135	109	90	88	33	19
TSC048E(1,3,4,W)	511	167	129	101	114	31	19
TSC060A(1,3,4,K,W)*	451	149	114	88	99	31	18
TSC060E(1,3,4,W)	561	183	142	111	125	31	19
TSC072A(3,4,K,W)*	681	236	177	119	150	38	21
TSC090A(3,4,K,W)*	754	257	188	129	180	37	22
TSC092A(3,4,W)*	756	261	202	131	162	39	21
TSC102A(3,4,K,W)*	835	281	223	149	181	40	21
TSC120A(3,4,K,W)*	880	298	238	158	187	40	21
THC036A1*	426	139	108	84	95	32	19
THC033A(3,4,W)*	457	139	108	84	95	32	19
THC036A(3,4,W)*	426	139	108	84	95	32	19
THC048A1*	468	146	113	97	111	31	20
THC043A(3,4,W)*	468	146	113	97	111	31	20
THC048A(3,4,W)*	468	146	113	97	111	31	20
THC060A1*	518	165	124	105	124	31	19
THC060A(3,4,W)*	506	164	121	100	122	31	19
THC063A(3,4,W)*	506	164	121	100	122	31	19
THC072A(3,4,W)*	718	235	182	128	173	38	22
THC092A(3,4,W)*	857	289	222	148	197	38	21
THC102A(3,4,W)*	893	294	233	159	207	39	22
THC120A(3,4,W)*	982	323	253	178	229	39	22

**Note:** Corner weights are given for information only. Unit is to be supported continuously by a curb or equivalent frame support.

**Table 2. Gas heating corner weights and center of gravity**

Unit Model	Net Weight (lbs)	Corner Wt. (lbs)				Center of Gravity (In.)	
		A	B	C	D	Length	Width
YSC036A1*(L,M,X,Y)	453	143	116	90	104	32	19
YSC036A1*(H,Z)	480	151	124	96	109	32	19
YSC036A(3,4,W)*(L,M,X,Y)	453	143	116	90	104	32	19
YSC036A(3,4,W)*(H,Z)	480	151	124	96	109	32	19
YSC036E(1,3,4,W)	532	165	137	95	134	31	19
YSC048A1*(L,M,X,Y)	478	151	122	102	103	33	19
YSC048A1*(H,Z)	505	159	130	108	109	33	19
YSC048A(3,4,W)*(L,M,X,Y)	465	146	121	101	97	33	19
YSC048A(3,4,W)*(H,Z)	492	154	129	107	103	33	19
YSC048E(1,3,4,W)	563	175	145	101	142	31	19
YSC060A1*(L,M,X,Y)	494	160	127	99	108	32	18
YSC060A1*(H,Z)	522	169	134	105	114	32	18
YSC060A(3,4,K,W)*(L,M,X,Y)	494	160	127	99	108	32	18
YSC060A(3,4,K,W)*(H,Z)	522	169	134	105	114	32	18
YSC060E(1,3,4,W)	613	190	158	110	155	31	19
YSC072A(3,4,K,W)*(L,X)	720	245	188	129	158	39	21
YSC072A(3,4,W)*(M,Y)	731	248	192	131	160	39	21
YSC072A(3,4,K,W)*(H,Z)	735	249	193	132	161	39	21
YSC090A(3,4,K,W)*(L,X)	804	269	203	142	190	38	22
YSC090A(3,4,W)*(M,Y)	808	270	204	143	191	38	22
YSC090A(3,4,K,W)*(H,Z)	820	273	208	146	193	38	22
YSC092A(3,4,W)*(L,X)	806	273	217	143	172	40	21
YSC092A(3,4,W)*(M,Y)	810	274	219	144	173	40	21
YSC092A(3,4,W)*(H,Z)	822	277	222	147	175	40	21
YSC102A(3,4,K,W)*(L,X)	883	293	238	161	191	40	21
YSC102A(3,4,W)*(M,Y)	887	294	239	162	192	40	21
YSC102A(3,4,K,W)*(H,Z)	899	297	243	165	194	40	21
YSC120A(3,4,K,W)*(L,X)	933	310	253	171	198	40	21
YSC120A(3,4,W)*(M,Y)	945	313	257	174	200	40	21
YSC120A(3,4,K,W)*(H,Z)	958	317	261	177	202	40	21
YHC036A1*(L,M,X,Y)	470	150	120	95	105	32	19
YHC036A1*(H,Z)	497	158	128	101	110	32	19
YHC033A(3,4,W)*(L,M,X,Y)	537	159	139	126	111	32	19
YHC036A(3,4,W)*(L,M,X,Y)	470	150	120	95	105	32	19
YHC033A(3,4,W)*(H,Z)	537	159	139	126	111	32	19
YHC036A(3,4,W)*(H,Z)	497	158	128	101	110	32	19

# Installation

**Table 2. Gas heating corner weights and center of gravity**

YHC048A1*(M,Y)	511	157	126	108	121	32	20
YHC048A1*(H,Z)	539	166	133	114	126	32	20
YHC043A(3,4,W)*(L,M,X,Y)	577	167	144	139	127	32	20
YHC048A(3,4,W)*(L,M,X,Y)	511	157	126	108	121	32	20
YHC043A(3,4,W)*(H,Z)	577	167	144	139	127	32	20
YHC048A(3,4,W)*(H,Z)	539	166	133	114	126	32	20
YHC060A1*(L,M)	562	176	137	116	133	31	20
YHC060A1*(H,Z)	574	179	140	119	136	32	20
YHC060A(3,4,W)*(L,M,X,Y)	550	175	133	110	131	31	19
YHC063A(3,4,W)*(L,M,X,Y)	612	180	151	144	137	31	19
YHC060A(3,4,W)*(H,Z)	561	178	137	113	134	31	19
YHC063A(3,4,W)*(H,Z)	561	178	137	113	134	31	19
YHC072A(3,4,W)*(L,X)	756	245	193	137	181	39	22
YHC072A(3,4,W)*(M,Y)	768	248	197	140	183	39	22
YHC072A(3,4,W)*(H,Z)	772	249	198	141	184	39	22
YHC092A(3,4,W)*(L,X)	907	302	238	161	207	39	22
YHC092A(3,4,W)*(M,Y)	911	303	239	162	208	39	22
YHC092A(3,4,W)*(H,Z)	923	306	243	165	210	39	22
YHC102A(3,4,W)*(L,X)	942	306	247	171	217	39	22
YHC102A(3,4,W)*(M,Y)	946	307	248	172	218	39	22
YHC102A(3,4,W)*(H,Z)	957	310	252	175	220	40	22
YHC120A(3,4,W)*(L,X)	1035	336	269	191	240	39	22
YHC120A(3,4,W)*(M,Y)	1047	339	272	194	242	39	22
YHC120A(3,4,W)*(H,Z)	1060	342	277	197	245	40	22

**Table 3. Heat pump corner weight and center of gravity**

WSC036A(1,3,4,W)*	442	138	110	88	105	31	19
WSC036E(1,3,4,W)	514	177	107	113	117	29	20
WSC048A(1,3,4,W)*	474	151	114	95	114	31	19
WSC048E(1,3,4,W)	525	181	109	115	119	29	20
WSC060A(1,3,4,W)*	492	160	118	97	117	31	19
WSC060E(1,3,4,W)	682	228	177	114	163	38	24
WSC060(A,B)(D,T)*	532	170	128	107	127	31	19
WSC072A(3,4,W)*	724	243	184	128	170	38	22
WSC072(A,B)(D,T)*	812	269	206	146	191	38	22
WSC090A(3,4,W)*	794	272	200	137	185	38	22
WSC090(A,B)(D,T)*	834	282	210	147	195	38	22
WSC120A(3,4,W)*	941	320	243	162	215	38	21
WSC120AT*	981	33	253	172	225	38	21

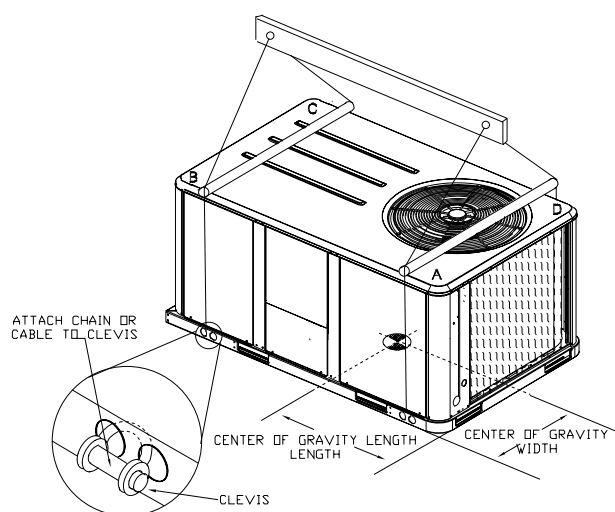

**Figure 17. Center of gravity**

## Installation

**Table 4. Accessory Weights – T\*C033-063A, TSC060B, Y\*C033-063A, YSC060B, T/YSC036E-060E, WSC036-060A, WSC036E-048E, WSC060B**

Option/ Accessory Description	Net lbs	Net kg
Electric Heat	15	6.8
Economizer	26	11.8
Motorized Damper	20	9.1
Manual Damper	16	7.3
Barometric Relief	7	3.2
Oversize Motor	5	2.3
Belt Drive Motor (3 phase only)	31	14.1
Hinged Access	10	4.5
Hail Guard	12	5.4
Through the Base Electrical	8	3.6
Through the Base: Gas	5	2.3
Unit Disconnect Switch	5	2.3
Unit Circuit Breaker	5	2.3
Conv. Outlet: Unpowered	2	0.9
Conv. Outlet: Powered	38	17.2
TCI, LCI	1	0.5
NOVAr	8	3.6
HPC	1	0.5
Frostat	1	0.5
Crankcase Heater	1	0.5
Smoke Detector, Return	7	3.2
Smoke Detector, Supply	5	2.3
Clogged Filter Switch	1	0.5
Fan Fail Switch	1	0.5
Discharge Air Tube	3	1.4
Roofcurb	70	31.7
Hard Start Kit	3	1.4
All Zone Sensors	1	0.5
Reheat Coil	15	6.8

**Table 5. Accessory Weights – T\*C072-120A, TSC072-120B, Y\*C072-120A, YSC072-120B, WSC060E, WSC072-120A, WSC072-090B**

Option / Accessory Description	Net lbs	Net kg
Electric Heat	30	13.6
Economizer	36	16.3
Motorized Damper	30	13.6
Manual Damper	26	11.8
Barometric Relief	10	4.5
Power Exhaust	80	36.3
Oversize Motor	8	3.6
Hinged Access	12	5.4
Hail Guard	20	9.1
Through the Base: Electrical	13	5.9
Through the Base : Gas	5	2.3
Unit Disconnect Switch	5	2.3
Unit Circuit Breaker	5	2.3
Conv. Outlet: Unpowered	2	0.9
Conv. Outlet: Powered	38	17.2
TCI, LCI	1	0.5
NOVAR	8	3.6
HPC	1	0.5
Frostat	1	0.5
Crankcase Heater	1	0.5
Smoke Detector, Return	7	3.2
Smoke Detector, Supply	5	2.3
Clogged Filter Switch	1	0.5
Fan Fail Switch	1	0.5
Discharge Air Tube	3	1.4
Roofcurb	115	52.2
LP Conversion Kit	3	1.4
All Zone Sensors	1	0.5
Reheat Coil	25	11.3





---

Literature Order Number	ACC-SVN43A-EN
Date	05/06
Supersedes	CURB-IN-36B
Stocking Location	Webb/Mason

The manufacturer has a policy of continuous product and product data improvement and reserves the right to change design and specifications without notice.